

Nominal voltage	12 V	
Nominal capacity	158,6 Ah @ C20 to 1,75 V/cell 150,1 Ah @ C10 to 1,80 V/cell	
Dimensions	Length	483 mm
	Width	170 mm
	Height / Total height	241 / 241 mm
Weight	~ 44,5 kg	
Technology	VRLA (Valve Regulated Lead Acid) AGM (Absorbent Glass Mat)	
Design life time	12 years (standby use)	
Internal resistance	~ 4,4 mΩ (full charged)	
Operating temperature range	Discharge	-20°C ~ +60°C
	Charge	0°C ~ +50°C
	Storage	-20°C ~ +60°C
Maximum discharge current	1 500 A (5 sek.)	
Short circuit current	2 700 A	
Recommended maximum charging current	45,0 A	
Charging voltage	Standby use	13,6 ~ 13,8 VDC
	Cycle use	14,6 ~ 14,8 VDC
Self discharge	Monthly is less than 3% at 25°C	
Container material	ABS UL94HB (optional UL94-V0)	
Terminal types	Internal thread M8 (breaking torque 10-12 Nm)	

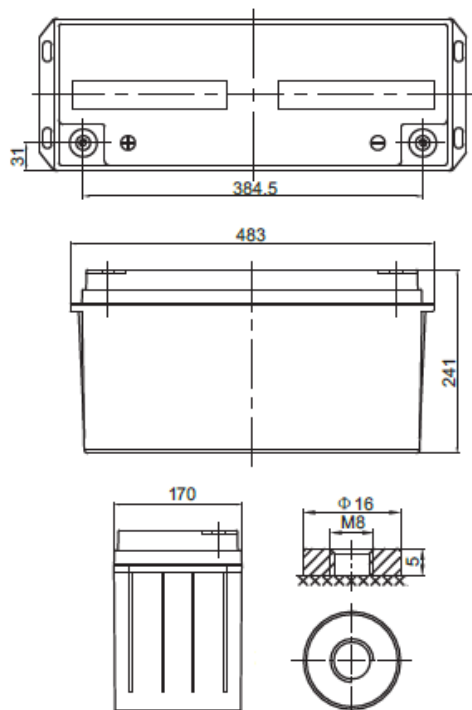

CONSTANT CURRENT DISCHARGE CHARACTERISTICS (A at 25°C)

Voltage / Time	5 min	10 min	15 min	30 min	1 h	2 h	3 h	4 h	5 h	8 h	10 h	20 h
9.6 V	473,69	331,62	260,96	157,38	92,35	55,33	41,04	33,33	28,14	18,80	15,99	8,20
10.0 V	456,58	321,73	254,12	153,92	90,64	54,52	40,49	32,92	27,81	18,61	15,84	8,13
10.2 V	434,31	308,78	245,13	149,35	88,38	53,44	39,77	32,37	27,38	18,36	15,64	8,05
10.5 V	405,72	292,00	233,42	143,37	85,40	52,02	38,80	31,64	26,81	18,02	15,37	7,93
10.8 V	369,65	270,57	218,37	135,62	81,51	50,14	37,53	30,67	26,04	17,58	15,01	7,78
11.1 V	325,30	243,77	199,36	125,72	76,50	47,71	35,88	29,41	25,05	16,99	14,54	7,57

CONSTANT POWER DISCHARGE CHARACTERISTICS (W at 25°C)

Voltage / Time	5 min	10 min	15 min	30 min	1 h	2 h	3 h	4 h	5 h	8 h	10 h	20 h
9.6 V	4892,0	3432,9	2778,3	1740,8	1051,7	638,6	477,3	389,7	330,3	223,6	191,4	98,3
10.0 V	4840,4	3418,9	2762,4	1728,0	1043,1	633,9	473,9	386,9	328,2	222,0	190,0	97,7
10.2 V	4655,7	3317,9	2688,0	1686,1	1020,5	623,3	466,5	381,3	323,7	219,3	187,7	96,8
10.5 V	4427,6	3194,1	2596,9	1635,3	991,1	609,5	457,2	374,1	318,0	215,7	184,7	95,5
10.8 V	4104,3	3011,3	2463,7	1562,5	950,5	590,5	444,0	364,0	310,1	210,9	180,6	93,7
11.1 V	3676,1	2761,2	2281,2	1462,8	898,4	564,8	426,3	350,3	299,2	204,3	175,2	91,4

According with:

PN-EN 60896-21:2007	ISO 9001
PN-EN 60896-22:2007	ISO 14001
PN-EN 61056-1:2013	
PN-EN 61056-2:2013	
PN-E-83016:1999	

EFFECT OF TEMPERATURE ON LONG TERM LIFE

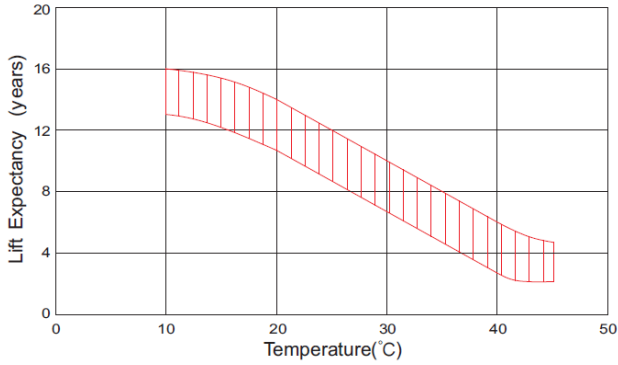

CYCLE LIFE IN RELATION TO DEPTH OF DISCHARGE

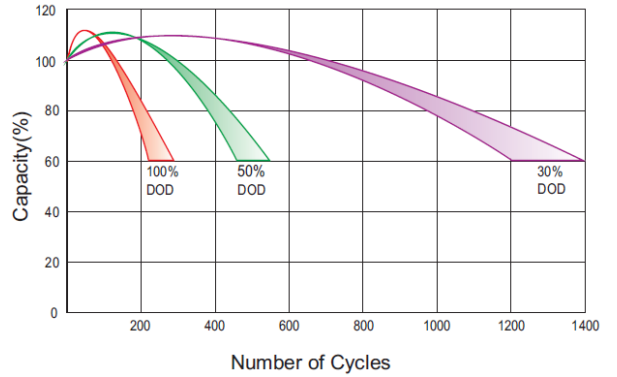

DISCHARGE CHARACTERISTICS

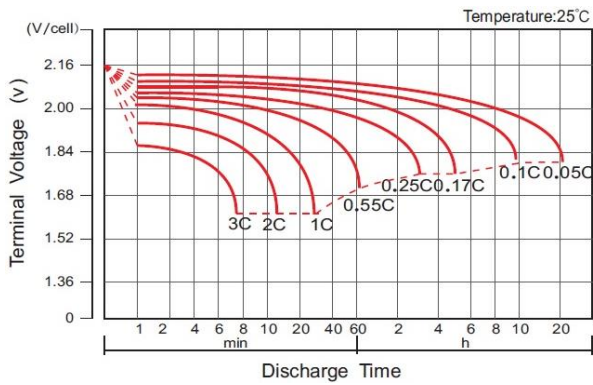

CHARGE CHARACTERISTIC FOR STANDBY USE

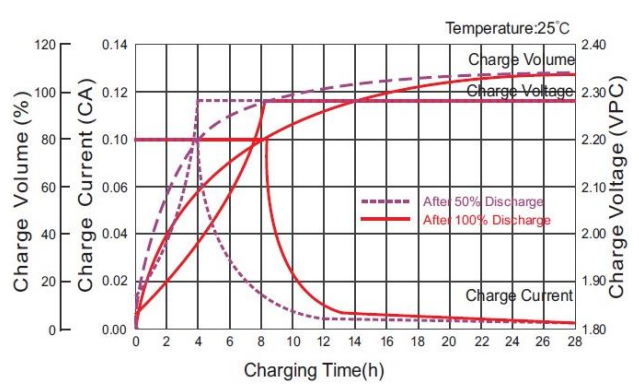

RELATIONSHIP BETWEEN CHARGING VOLTAGE AND TEMPERATURE

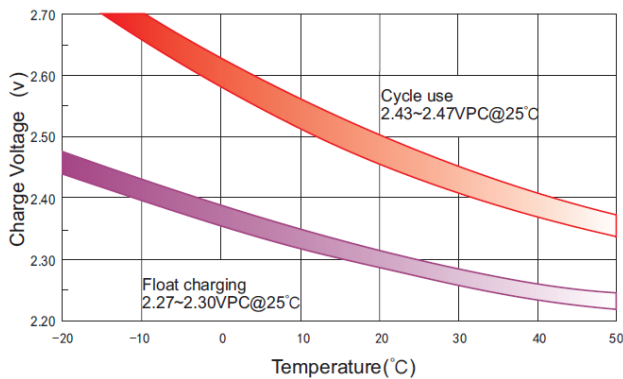

STORAGE CHARACTERISTICS

